

AS2000-B3-V240-DD Scroll Air System

System is NFPA compliant and has modular construction and interconnecting piping.

PUMP MODULE

The belt driven oil-less scroll compressors deliver pressures up to 115 psi. Each scroll module includes two compressors driven by a common motor; drive belts with belt guard; inlet filter; isolation valve; aftercooler; temperature switch and relief valve.

AIR TREATMENT MODULE

The system's air treatment module features dual desiccant dryers configured for energy savings. They purge only when needed per the dew point setting. The dew point transducer and CO transducer are integrated with the electrical panel. The module also contains prefilters, after filters, and activated carbon filters. Final line pressure regulators with gauges and relief valves are also part of the air treatment module.

AIR RECEIVER

The receiver is constructed to ASME standards and is epoxy lined for corrosion resistance. A source isolation valve and 3 valve bypasses are provided with the receiver module. A pressure gauge and relief valve are included, along with a sight window and electric auto drain. Mounting pads and flexible connectors are provided.

CONTROL PANEL

The UL listed electrical control panel features a high-definition color touch screen that can be set up externally without the use of toggle switches. The panel displays multiple conditions, including compressor running status, elapsed hours, pressure level, and audio/visual alarms.

Standard features include lag alarm, automatic compressor alternation, adjustable minimum run timer, adjustable pressure settings, adjustable screen brightness, alarm history registry, and data logging. The panel has standard dry contacts and Modbus interface with building management systems. Ethernet and BACnet are available as options. The panel's maintenance menu includes service items and maintenance warnings, and it is programmed for both English and Spanish languages.

Configuration	Triplex Base Mount
System Capacity*	137.2 SCFM @ 50 psi 60 Hz. 137.2 SCFM @ 50 psi 50 Hz.
Horsepower (Each Pump)	20 HP
Horsepower (Total System)	60 HP
Available Voltage	208/230/460V 3 PH 60 Hz. 380V 3 PH 50 Hz. Contact Factory for other voltages
Full Load Amps 3 ph.	208 Volts: 186.6 230 Volts: 169.6 380 Volts: 100.7 460 Volts: 85
Tank Size	240 gallon vertical
Key Options	Bacterial filters for dryer/filter skid Can be configured for lab use without lag alarm Expandable for additional compressors

Scan here for compressor specifications and industry-leading parts support.



*System capacity is stated with one pump in reserve per NFPA. Capacity based on operation at sea level. For higher altitude, contact factory for adjusted capacity.

SYSTEM MODEL NO.	PART NO.	HP EACH	SCHEMATIC @ 50 PSIG EACH	VCF/VAL/FA @ 100 PSIG EACH	DESIGN CAPACITY (E 50PSIG EACH)	RECEIVER SIZE (GALLONS)	PUMP DISCHARGE NPT	ESTIMATED SYSTEM WEIGHT (LBS)
AS2008-83-DD	AS2000-440-83-V240-DD	20	69.6	87.6	137.2	240	3/4"	4400

SPACE ALLOWANCE FOR MAINTENANCE = 3 FT ON ALL SIDES, MORE SPACE REQUIRED FOR OPENING OF LARGER PANEL DOOR.

TABLE 1			
SYSTEM LISTED ARE 460V. IF ANOTHER VOLTAGE IS REQUIRED, USE THE FOLLOWING PART NUMBERS.			
VOLTAGE	SYSTEM P/N	PUMP MODULE P/N	TRIP MODULE P/N
208-40-3	AS2000-208-83-V240-DD	100-0269	214339
230-40-3	AS2000-230-83-V240-DD	100-0269	214339
380-50-3	AS2000-380-83-V240-DD	100-0269	214546

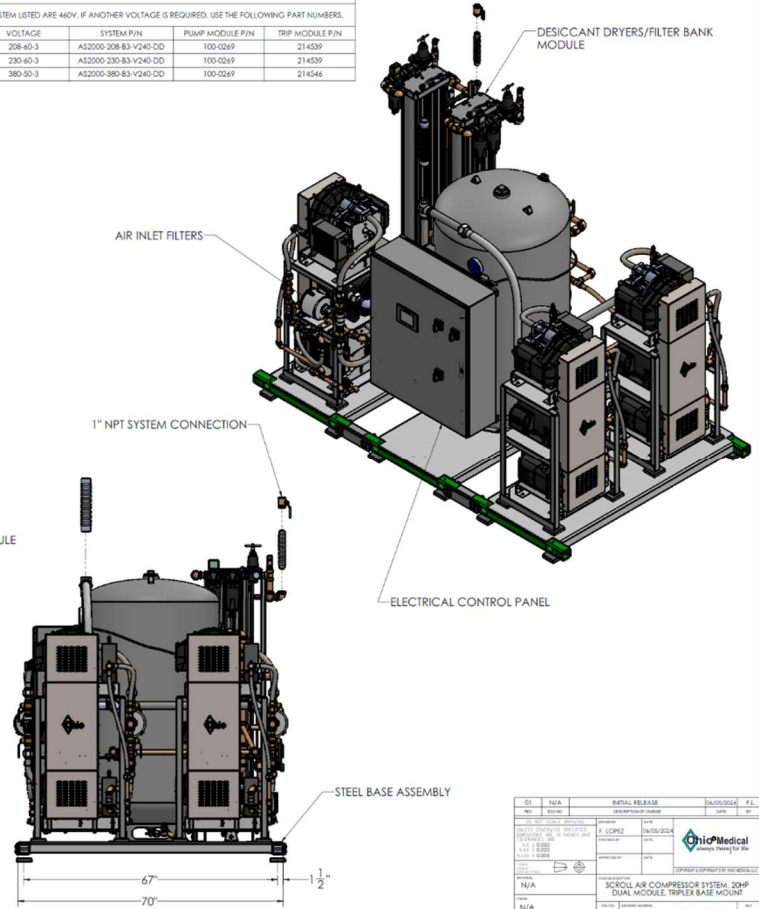
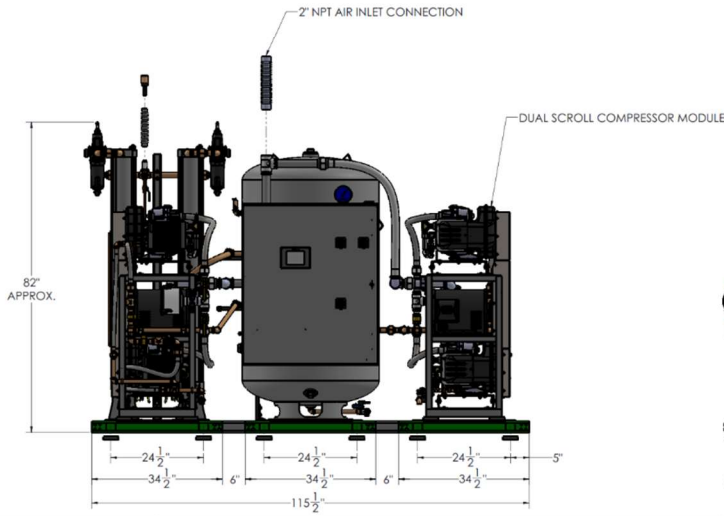
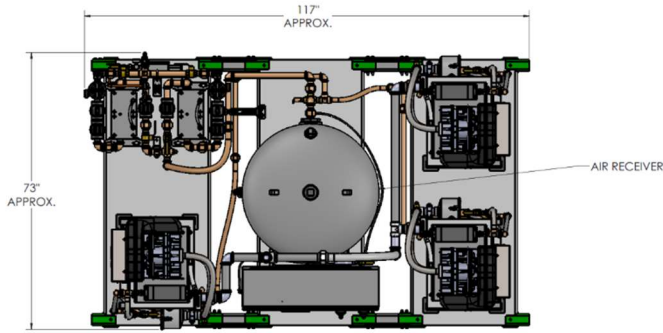

QTY	N/A	RETAIL RELEASE	DATE/REV	P.L.
1		AS2000-440-83-V240-DD	04/05/2024	01
SCROLL AIR COMPRESSOR SYSTEM, 20HP DUAL MODULE, TRIPLEX BASE MOUNT				
N/A				
B AS2000-440-83-V240-DD-5 01				
SCALE 1:16 SHEET 1 OF 1				